

TBH Series

25 Watt TO220 Package Thick Film Power



Ohmite's TBH25 TO220 style resistors are designed for a variety of uses that require intermediate heatsinkable power at an economical price. Engineered for industrial applications, these resistors deliver reliable performance to traditional high-quality Ohmite standards.

FEATURES

- 25 Watts, @ 25°C case temperature
- Non-Inductive Performance
- Low Thermal Resistance
- Anti-static tube packaging available
- Economically priced
- Resistance element is electrically insulated from metal heat sink mounting tab

APPLICATIONS

- Power Supplies
- Industrial Controls
- Automotive Steering
- Pre-load/Damping
- Snubber/Bleeder
- Current Sensing

CHARACTERISTICS

Resistor	Thick film element above 1Ω, Ni-Cu metal element below 1Ω	Test	Condition	Result
Case	High Temperature Plastic	Load Life	(1000hrs @ rated power)	max. ΔR ±1%
Terminals	Solder coated phosphor bronze	Moisture Resistance	(MIL-STD-202, method 106)	max. ΔR ±0.5%
Derating	100% @ 25°C to 0% @ 150°C curve referenced to case temperature	Short Time Overload	(2x rated power, not to exceed 1.5x max. operating voltage)	max. ΔR ±0.3%
Dielectric Strength	1000 VDC	Solderability	(MIL-STD-202, method 208)	
Max. Mounting Torque	0.9Nm	Thermal Shock	(MIL-STD-202, method 107, cond. F)	max. ΔR ±0.3%
Operating Temperature Range	-55°C to +150°C	Terminal Strength	(MIL-STD-202, method 211, cond. A (pull test) 2.4N)	max. ΔR ±0.2%
Temperature Coefficient	0.1-10Ω @ ±200ppm 11Ω-10KΩ @ ±50ppm	Vibration	(MIL-STD-202, method 204, cond. D)	max. ΔR ±0.2%
Thermal Resistance	5°C/W			
Tolerance	5%			
Power	25 Watts. Rating based on 25°C case temperature. The case temperature is to be used for the purposes of establishing the applied power limit. The case temperature must be made with thermocouple contacting the center of the component's mounting tab mounted on designated heat sink.			
Resistance Range	0.1Ω - 10KΩ. Standard values listed at left, others available upon special request.			
Max. Operating Voltage	350V			

(continued)

TBH Series

25 Watt TO220 Package Thick Film Power

DIMENSIONS

(mm)

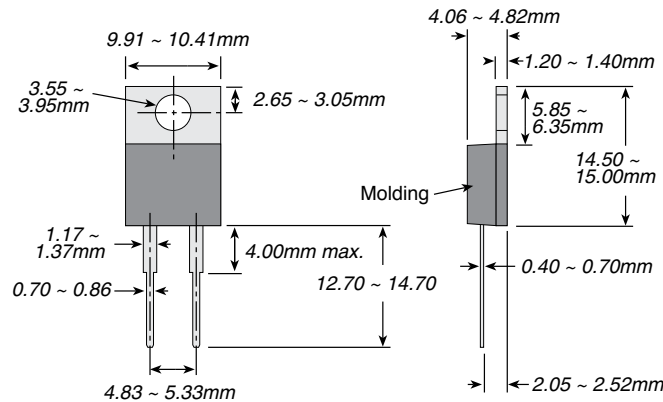

Note: These dimensions apply to TBH products manufactured after June 10, 2016

ORDERING INFORMATION

RoHS compliant Non-RoHS version unavailable		
T B H 2 5 P 2 R 0 0 J E		
Series	Ohm Value Example: R100 = 0.1Ω 10R0 = 10Ω 1K50 = 1500Ω	Tolerance J = 5%, standard

Standard Part Numbers

Ohms	Part Number 5% Tolerance	Ohms	Part Number 5% Tolerance
2	TBH25P2R00JE	100	TBH25P100RJE
7.5	TBH25P7R50JE	150	TBH25P150RJE
10	TBH25P10R0JE	220	TBH25P220RJE
15	TBH25P15R0JE	240	TBH25P240RJE
22	TBH25P22R0JE	330	TBH25P330RJE
30	TBH25P30R0JE	470	TBH25P470RJE
33	TBH25P33R0JE	510	TBH25P510RJE
47	TBH25P47R0JE	1000	TBH25P1K00JE
51	TBH25P51R0JE	1500	TBH25P1K50JE
75	TBH25P75R0JE	2000	TBH25P2K00JE
		2700	TBH25P2K70JE
		10,000	TBH25P10K0JE

THIS PRODUCT IS DESIGNED FOR USE WITH PROPER HEATSINKING.

Maximum base plate temperature of the resistor must be monitored and kept within specified limits to establish the power rating. Best technique is to attach a thermocouple to the side of the base plate of the resistor. Temperature of plastic housing or heat sink cannot be used to establish rating of the resistor.